

# Cylinder Specifications

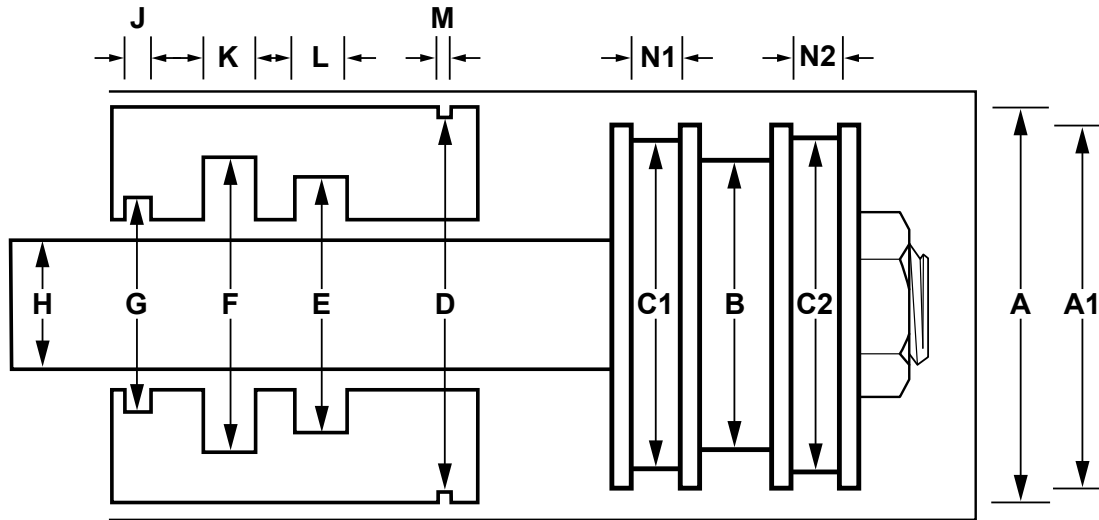

- A** \_\_\_\_\_ Cylinder Bore
- A1** \_\_\_\_\_ Piston Diameter
- B** \_\_\_\_\_ Piston Seal Groove Diameter
- C1** \_\_\_\_\_ Wear Ring Groove Diameter
- C2** \_\_\_\_\_ Wear Ring Groove Diameter
- D** \_\_\_\_\_ O-Ring Groove Diameter
- E** \_\_\_\_\_ Buffer or Wear Ring Groove Dia.
- F** \_\_\_\_\_ Rod Seal Groove Diameter

- G** \_\_\_\_\_ Wiper Groove Diameter
- H** \_\_\_\_\_ Rod Diameter
- J** \_\_\_\_\_ Wiper Groove Width
- K** \_\_\_\_\_ Rod Seal Groove Width
- L** \_\_\_\_\_ Buffer or Wear Ring Groove Width
- M** \_\_\_\_\_ O-Ring Groove Width
- N1** \_\_\_\_\_ Wear Ring Groove Width
- N2** \_\_\_\_\_ Wear Ring Groove Width